

ISO 1552  
PNEUMATIC CYLINDERS  
PNC SERIES Ø32 - Ø125





**PNC SERIES**  
ISO 15552 - Ø32 - Ø125

CUSHIONING CYLINDER

LONG-LASTING AND  
ALSO INEXPENSIVE

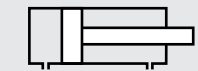

**PNC:** DOUBLE ACTING CYLINDER

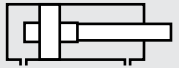

**PNC-Y:** DOUBLE ACTING CYLINDER  
WITH CUSHIONING

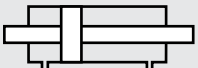

**PNC-D:** DOUBLE ACTING CYLINDER  
WITH DOUBLE ROD

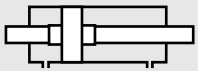

**PNC-YD:** DOUBLE ACTING CYLINDER  
WITH CUSHIONING AND DOUBLE ROD

**Example of order:**

PNC-Y  
Product Code

050-0100  
Cylinder Ø  
Stroke

FLM  
Cylinder  
Mountings

K4  
Variants from  
Standard System

**VARIANTS FROM STANDARD SYSTEM:**

- R1: Stainless Steel Piston Rod (SS 304-SS 316)
- R3: Stainless Steel Screws for Cylinder Covers (SS 304)
- R4: Stainless Steel Nut for Piston Rod (SS 304)
- M1: Extended male Piston Rod Thread
- M2: Female Piston Rod Thread
- M3: Special Piston Rod Thread
- M4: Extended Piston Rod
- E1: Hard Eloxal Plated, Anticorrosive Aluminium Covers
- K1: Seals for Max. 150°C (Viton)
- K2: Piston Rod Seal NBR + PA
- K3: Seals NBR
- K4: Piston Rod Seal Viton

**Working Fluid:**

Filtered and lubricated air

**Operating Temperature Range:**

NBR+Polyurethane (PU): (-20°C) - (+80°C)  
Viton (FKM) : (-30°C) - (+150°C)

**Max. Work Pressure:**

10 Bar

**Force:**

Cylinder Ø mm	Rod Ø mm	Thrust and traction forces(6 Bar)	
		Thrust Force (N)	Traction Force (N)
32	12	482	415
40	16	754	633
50	20	1178	990
63	20	1870	1682
80	25	3016	2721
100	25	4712	4418
125	32	7363	6881

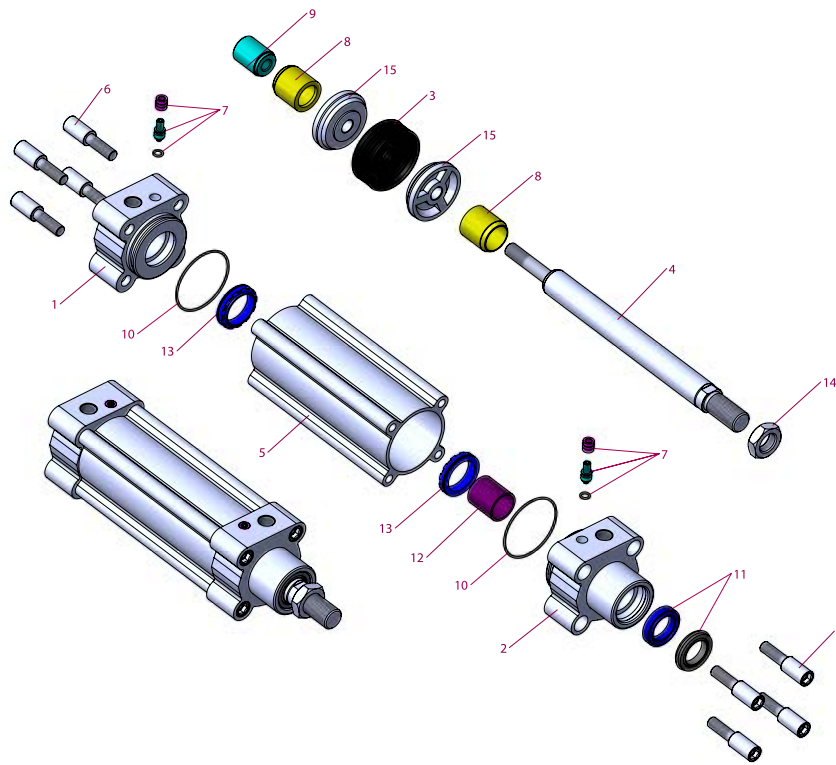
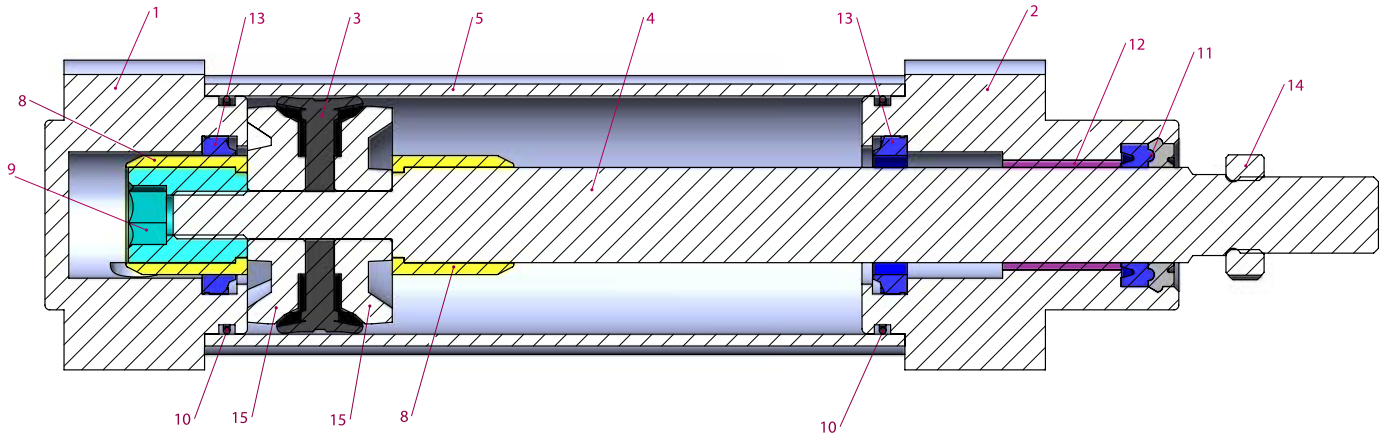

No	MATERIAL NAME	CHARACTERISTIC	PC.
1	Rear Head	Aluminium	1
2	Front Head	Aluminium	1
3	Piston Seal	NBR	1
4	Piston Rod	CK 45 Hard Chrome Plated	1
5	Tube	Al Mg Si 0,5 + Eloxal Plated	1
6	Bolt	Galvanized Steel	8
7	Cushioning Screw	Brass+AISI 303 NBR	2
8	Cushioning Plastic	Polycetal	2
9	Cushioning Fem. Thread	Galvanized-Plated Steel	1
10	Head O-ring	NBR	2

No	MATERIAL NAME	CHARACTERISTIC	PC.
11	Rod Seal	HYTREL + PU	1
12	Guiding Bush	CSB-40	1
13	Cushioning Seal	PU	2
14	Nut	Galvanized Steel	1
15	Piston Seal Washer	Aluminium	2

**Note:**

Dia 32: Instead of Cushioning Plastic is used Cushioning yellow and instead of Cushioning Plastic Female Thread is used Cushioning yellow Female Thread. [Material:Brass]

Dia 125: Instead of Cushioning Plastic is used Cushioning Aluminium and instead of Cushioning Plastic Female Thread is used Cushioning Aluminium Female Thread. [Material: Anodized Aluminium]

The Piston Seal Washers exist only as Ø32, Ø40, Ø50

The Parts [Nr. 7, 8, 9, 13] don't exist in the Models Without Cushioning. Fibre Nut and Washer exist instead of the Part Nr. 9

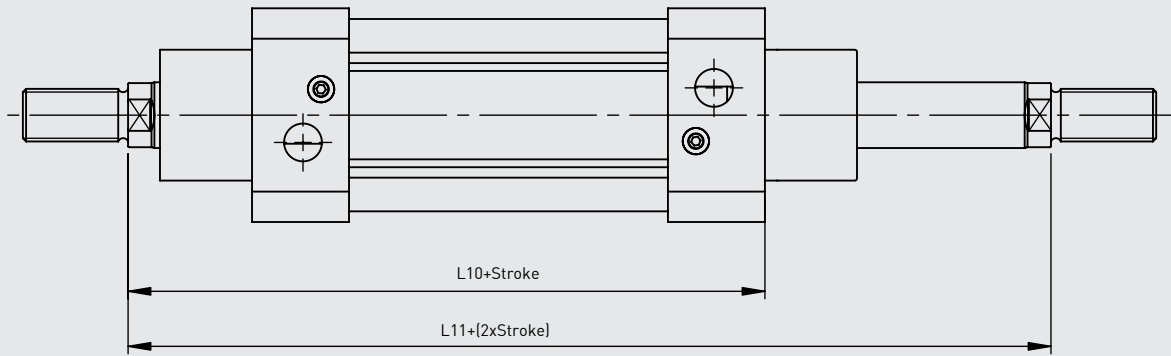
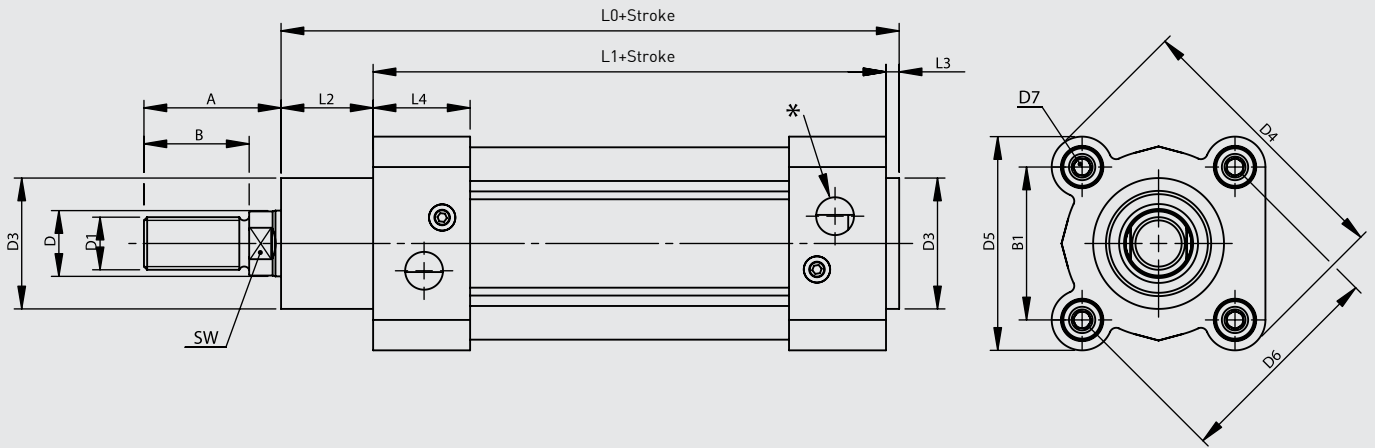

Cylinder Ø mm	A	B	B1	D Ø	D1	D3 Ø	D4	D5	D6 Ø	D7	L0	L1	L2	L3	L4	L10	L11	SW	*
32	30	22	32,5	12	M10x1.25	30	58,5	45	46	M6	116	94	18	4	25	120	146	10	G1/8"
40	34	24	38	16	M12x1.25	35	69,7	54	53,7	M6	129	105	20	4	27	135	165	13	G1/4"
50	41	32	46,5	20	M16x1.5	40	84,2	65	65,7	M8	138	106	28	4	29,5	143	180	17	G1/4"
63	42	32	56,5	20	M16x1.5	45	99,5	76	80	M8	152	121	27	4	34,5	158	195	17	G3/8"
80	52	40	72	25	M20x1.5	45	123,8	94	101,8	M10	167	128	34	4	35	174	220	22	G3/8"
100	52,5	40	89	25	M20x1.5	55	148,8	112	125,9	M10	182,5	138	38,5	4	38	189	240	22	G1/2"
125	73	54	110	32	M27x2	60	180,5	135	155,5	M12	213	160	46	6	44	225	290	27	G1/2"

**FLM Flange Mounting**

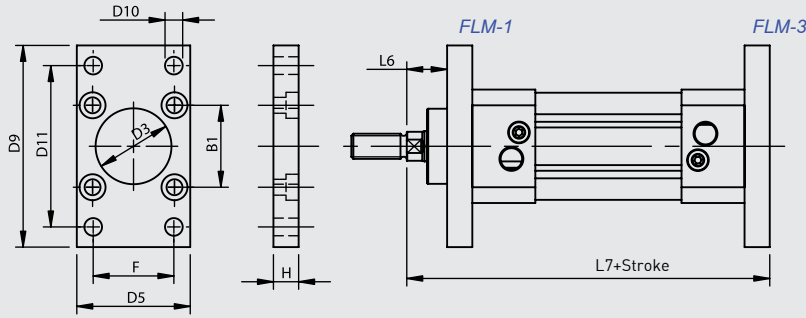

**CTHM Central Trunnion Head Mounting**

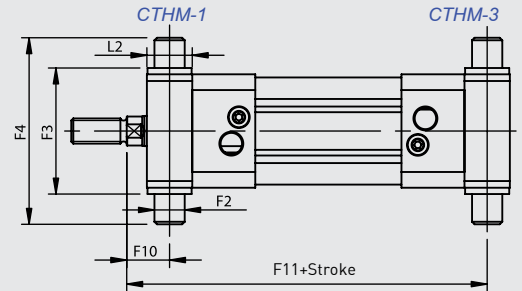

**FM Foot Mounting**

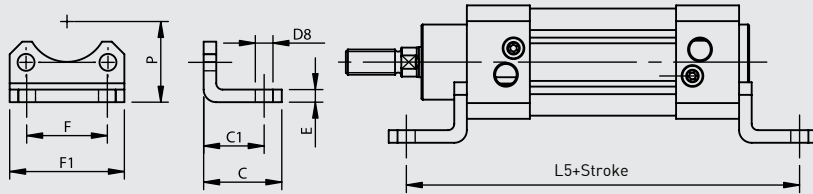

**CTM-3 Central Trunnion Mounting**

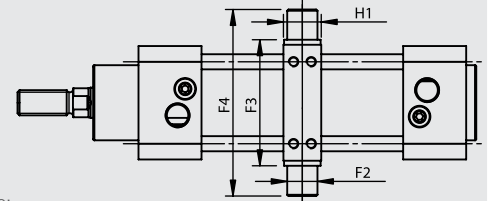

Note:  
Adjustable CTM Connection for Models; Round Tube+Tie-Rod

**SF Swivel Flange**

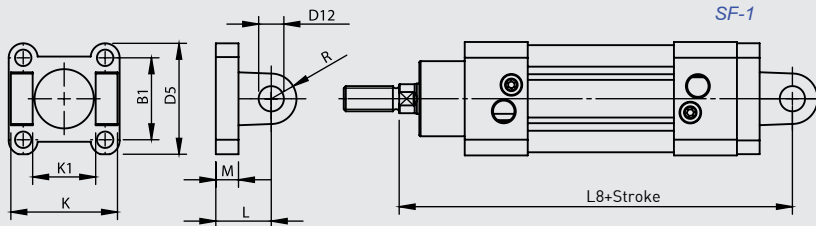

**TSM Trunnion Support Mounting**

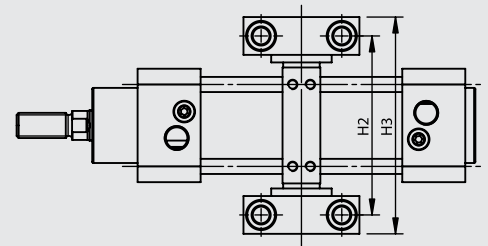

**CFM Clevis Foot Mounting**

**SFWCFM Swivel Flange with Clevis Foot Mounting**

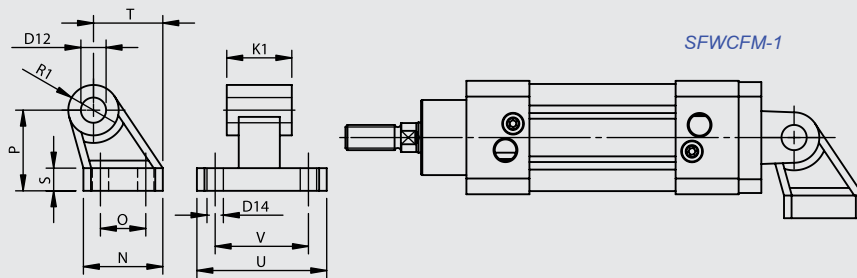

Cylinder Ø mm	B1	C	C1	D3 Ø H11	D5	D8 Ø H14	D9	D10 Ø H13	D11 JS14	D12 Ø H9	D14 Ø H13	E	F	F1	F2 Ø e9	F3 h14	F4	F5 ±0,2	F6	F7	F8	F9 Ø H13	F10	F11
32	32.5	30	24	30	45	7	80	7	64	10	6.6	5	32	45.5	12	50	74	32	46	30	6.8	6.6	17	129
40	38	37	28	35	54	10	90	9	72	12	6.6	5	36	54.5	16	63	95	36	55	36	9	9	20	145
50	46.5	41	32	40	65	10	110	9	90	12	9	6	45	65	16	75	107	36	55	36	9	9	23	157
63	56.5	44	32	45	76	10	120	9	100	16	9	6	50	76	20	90	130	42	65	40	11	11	23.5	171.5
80	72	56	41	45	94	12	150	12	126	16	11	6	63	94	20	110	150	42	65	40	11	11	29	191
100	89	58	41	55	112	14	175	14	150	20	11	6	75	112	25	132	182	50	75	50	13	14	31.8	208.3
125	110	67	45	60	134	16	210	16	180	25	14	8	90	131	25	160	210	50	75	50	13	14	42	248

Cylinder Ø mm	H	H1	H2	H3	H4	H5 Ø H13	H6	K h14	K1 H14	L	L2	L5	L6	L7	L8	M	N	O JS14	P JS16	R	R1	S	T	U	V JS14
32	10	15	71	86	15	11	10.5	45	26	22	18	142	16	130	142	9	31	18	32	10	10	8	27.5	51	38
40	10	20	87	105	18	15	12	52	28	25	20	161	20	145	160	9	35	22	36	12	11	10	30.5	54	41
50	12	20	99	117	18	15	12	60	32	27	28	170	25	155	170	11	45	30	45	13	13	12	40.5	65	50
63	12	25	116	136	20	18	13	70	40	32	27	185	25	170	190	11	50	35	50	16	15	12	44.5	67	52
80	16	25	136	156	20	18	13	90	50	36	34	210	30	190	210	14	60	40	63	16	15	14	57	86	66
100	16	30	164	189	24.5	20	16	110	60	41	38.5	220	35	205	230	14	70	50	71	20	19	15	65	96	76
125	20	32	192	217	24.5	20	16	130	70	50	46	250	45	245	275	15	90	60	90	25	22.5	20	85	124	94

**FLM Flange Mounting**

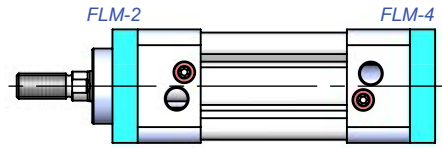
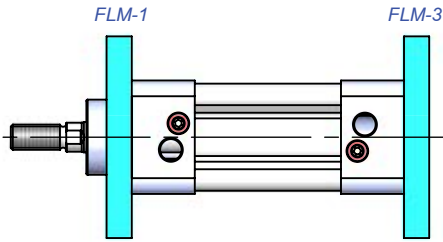

**FM Foot Mounting**

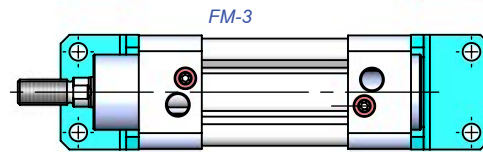
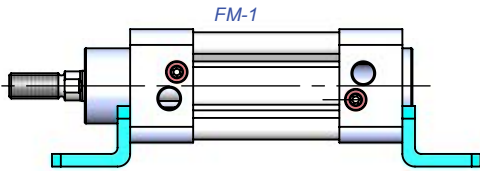

**SF Swivel Flange**

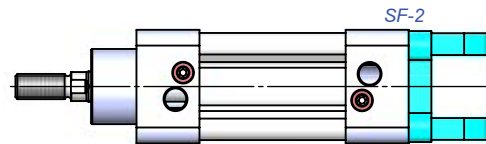
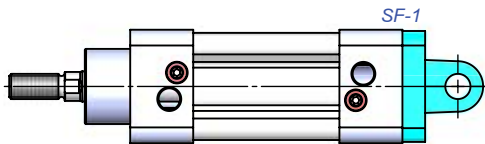

**SFWCFM Swivel Flange with Clevis Foot Mounting**

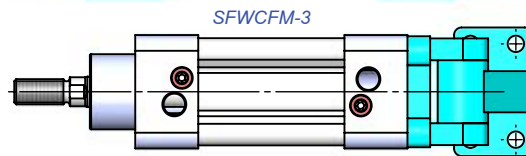
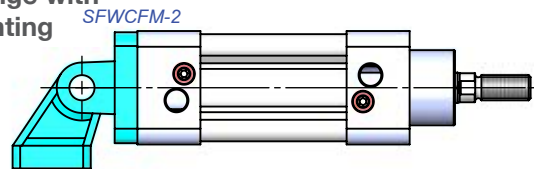
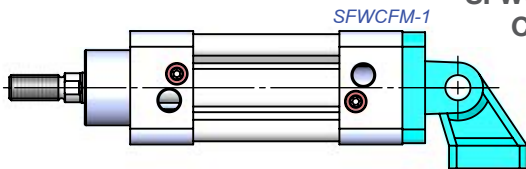

**CTHM Central Trunnion Head Mounting**

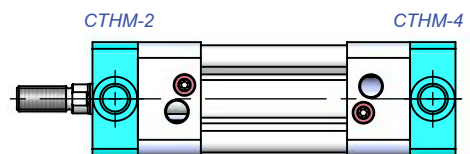
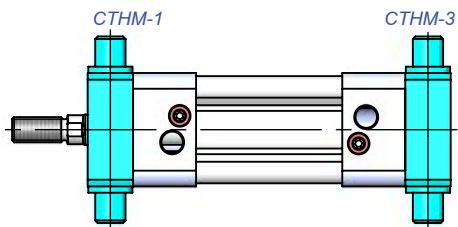

**CTM Central Trunnion Mounting**

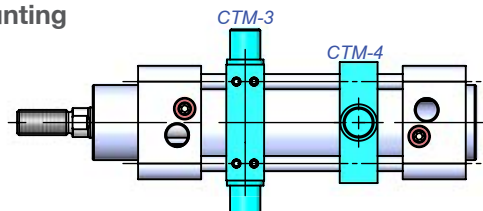
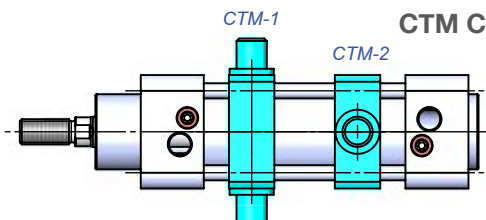

CTM-1-2 Fixed Connection

CTM-3-4 Adjustable Connection

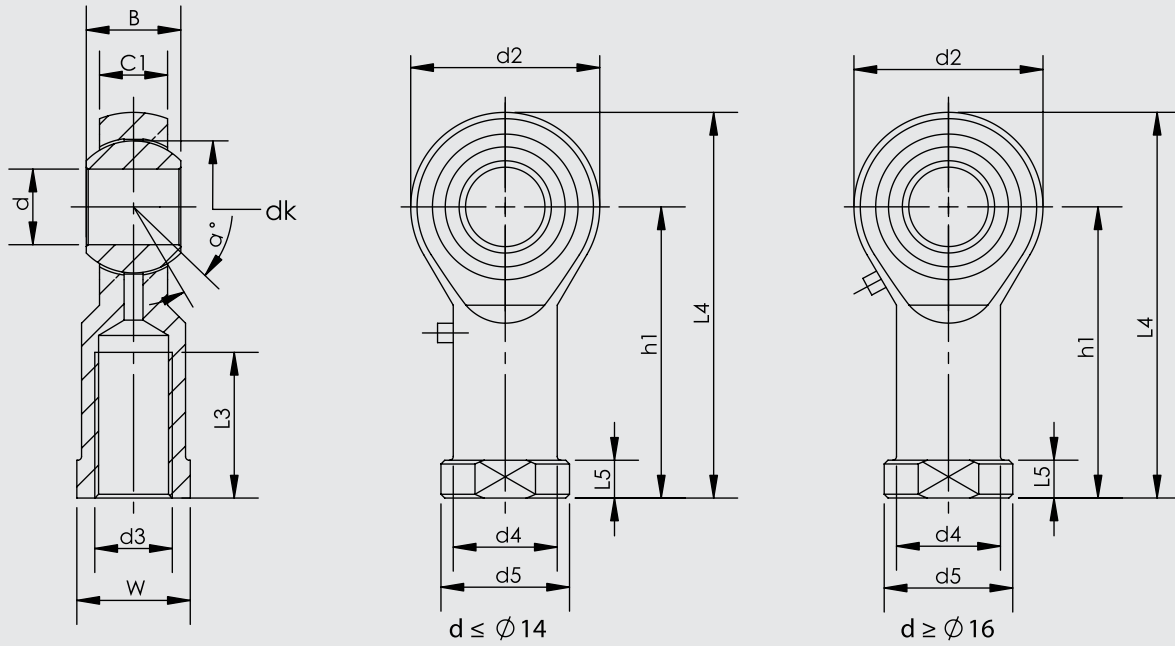

Part No.	Dimensions (mm)													
	$d$	$d3$ 6H	$B$	$C1$	$W$	$L3$ min	$d2$	$L4$	$h1$	$L5$	$d4$	$d5$	$dk$	$a^\circ$
KMB 10 -1	10	M10x1.25	14	10.5	17	20	26	56	43	6.5	15	19	19.05	13
KMB 12 -1	12	M12x1.25	16	12	19	22	30	65	50	6.5	17.5	22	22.225	13
KMB 16 -1	16	M16x1.5	21	15	22	28	40	84	64	8	22	27	28.575	15
KMB 20	20	M20x1.5	25	18	30	33	50	102	77	10	27.5	34	34.925	14
KMB 28	28	M27x2.0	35	24	41	48	66	136	103	14	37	46	47.6	15
KMB 30-1	30	M27x2.0	37	25	41	51	70	145	110	15	40	50	50.8	17
KMB 30	30	M30x2.0	37	25	41	51	70	145	110	15	40	50	50.8	17

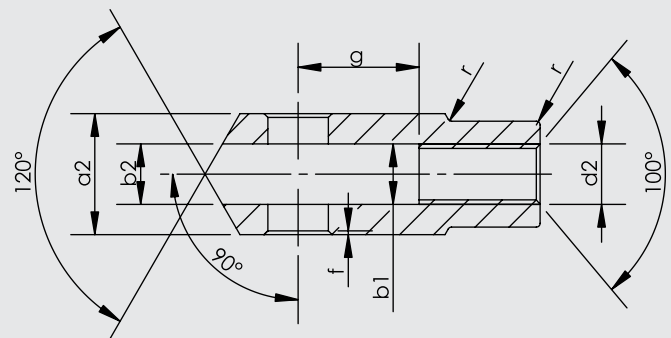
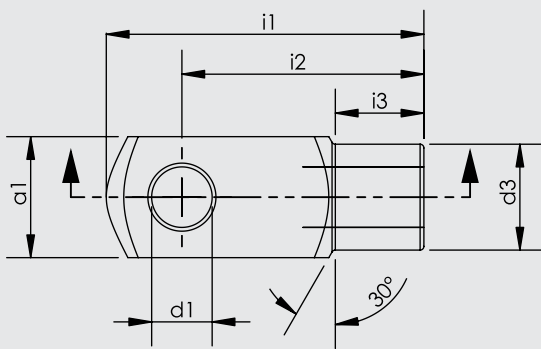

Cylinder $\phi$ mm	$d1$ H9	$g$ $\pm 0,5$	$a1$ h 11	$a2$ $+0,3$ $-0,16$	$b1$ B 13	$b2$	$d2$ 6H	$d3$ $\pm 0,3$	$f$ $\pm 0,2$	$i1$ $\pm 0,5$	$i2$	$i3$ $\pm 0,2$	$r$
32	10	20	20	20	10	10	M10x1.25	18	0.5	52	40	15	0.5
40	12	24	24	24	12	12	M12x1.25	20	0.5	62	48	18	0.5
50	16	32	32	32	16	16	M16x1.5	26	1	83	64	24	1
63	16	32	32	32	16	16	M16x1.5	26	1	83	64	24	1
80	20	40	40	40	20	20	M20x1.5	34	1.5	105	80	30	1.5
100	20	40	40	40	20	20	M20x1.5	34	1.5	105	80	30	1.5
125	25	50	50	50	25	25	M27x2	42	1.5	132	100	36	1.5